

in the same alcohols. The monomolecular reaction velocity decreased with increasing molecular weight of the solvent.

The reaction velocity in the pure alcohols decreased with increasing number of oxy groups in the alcohol. The velocity was very much higher in ethyl alcohol than in ethylene glycol solutions. The addition of dextrose with five oxy groups decreased the velocity very rapidly to values too small to be measured accurately. The velocity in solutions of isomeric alcohols is greatest for the form with the most compact alkyl group. Again Goldschmidt and co-workers found the contrary. The velocity of formation of an ester catalyzed by one of the halide acids is highest for the normal form.

The reaction velocity in solutions of some of the pure alcohols is largely influenced by the presence of small amounts of water. This influence decreases with decreasing molecular weight of the alcohol or with increasing number of oxy groups. It seems to be rather small for methyl alcohol, ethylene glycol and polyvalent alcohols. The curves for the reaction velocity in water-alcohol mixtures showed in all cases a continuous variation. Sharp bends or other peculiarities did not seem to be present.

Summary

The decomposition velocity of diacetone alcohol at 25° with 0.1 *N* sodium hydroxide as catalyst has been measured in varying water mixtures of a number of different alcohols. A short discussion of the results has been given.

PHILADELPHIA, PENNSYLVANIA

[CONTRIBUTION FROM THE BUREAU OF CHEMISTRY AND SOILS, DEPARTMENT OF AGRICULTURE]

THE COMPRESSIBILITY ISOTHERMS OF HYDROGEN, NITROGEN AND A 3:1 MIXTURE OF THESE GASES AT TEMPERATURES BETWEEN 0 AND 400° AND AT PRESSURES TO 1000 ATMOSPHERES

BY EDWARD P. BARTLETT, H. L. CUPPLES AND T. H. TREMEARNE

RECEIVED DECEMBER 23, 1927

PUBLISHED MAY 5, 1928

This report is the fourth of a series from this Laboratory concerning the physical properties of hydrogen, nitrogen and their mixtures at high pressures.¹ In it are presented the results of a continuation of a study of compressibility phenomena of hydrogen and nitrogen through the temperature range from 0 to 400°.

Method.—A quantity of gas at known pressure and temperature is confined in a heavy steel pipet of known capacity. This gas is allowed to expand into a gas buret maintained at constant temperature and the

¹ (a) Bartlett, *THIS JOURNAL*, **49**, 65 (1927); (b) **49**, 687 (1927); (c) **49**, 1955 (1927).

quantity of gas determined by measurement of a fixed volume at a measured pressure not far above or below atmospheric pressure.

Preparation and Purification of the Gases.—As in the earlier work, hydrogen is prepared by the electrolysis of a solution of potassium hydroxide, and nitrogen is obtained from the fractional distillation of liquid air. The argon content of the nitrogen is believed by the manufacturers not to

exceed 0.05%.² The 3:1 hydrogen–nitrogen mixture is prepared by “cracking” anhydrous ammonia on an ammonia catalyst at 700° and removing uncracked ammonia by means of a water scrubber. A suitable purification train described in a previous report provides for the removal of water vapor and traces of oxygen.

Apparatus.—Only such changes have been made in the apparatus already described^{1b} as are required to meet the changed temperature conditions. The temperature of the pipet is maintained by means of a stirred and thermostatically controlled bath of brine, water, light oil, heavy oil or molten eutectic lead–tin mixture, depending upon the temperature. At 300 and 400° manual regulation of temperature has been found to be more satisfactory.

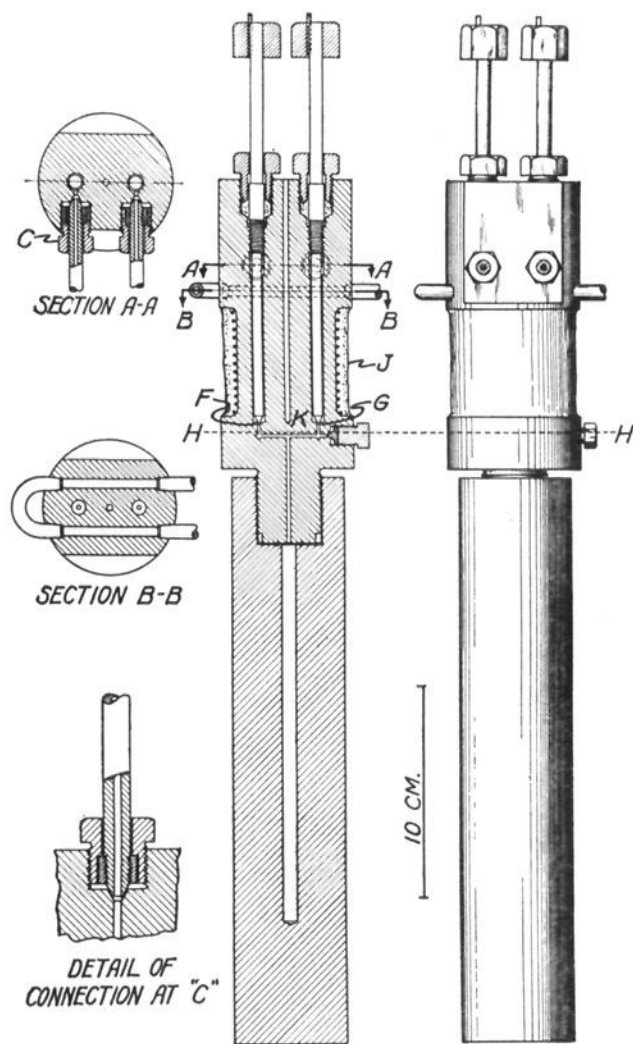

Fig. 1.—High temperature pipet.

Pipets such as were described in a previous paper are satisfactory at the temperatures below 200°. They are of chrome vanadium steel containing 1.3% Cr, 0.2% V and 0.2–0.3% carbon. At the temperatures above 200° cooling of the valve stem threads is essential and the valve stems themselves must be of a material which retains its hardness. A 13% chromium steel fulfils well this requirement. After a number of stages in development a pipet has been designed which not only is satisfactory for work at 400° but seems best suited also for work at any lower temperature.

² The actual argon content of nitrogen made by rectification of liquid air is now being investigated by this Laboratory.

The compressed gas enters the pipet (Fig. 1) at F and is released at G. There is no possible error from gas trapped in valve stem packings. Valve leakage is quickly detected by means of a bubbler in the expansion line. The pipet is immersed in the bath to the depth HH. The valve stems are water cooled at BB. By means of the electrical heating unit J, heat is applied until a thermocouple at K registers the bath temperature. It is assumed that this precaution assures a uniform temperature throughout the entire body of the trapped gas.

Calibration.—All apparatus on which the accuracy of data depends has been carefully calibrated. Special mention will be made of the methods employed in calibrating the steel pipets and the dead-weight pressure gages.

The Laboratory is provided with a steel pipet of 27.38 cc. capacity which has been calibrated with mercury, both by this Laboratory and the Bureau of Standards. This pipet and the pipet to be calibrated are connected in parallel to the apparatus and filled with gas of the same composition at identical pressure and temperature (usually 100 atmospheres and 0°). After the small correction for change in capacity with change in pressure has been applied, the ratio of the pipet sizes is the ratio of the expanded volumes of gas from the two pipets. After establishing the compressibility of hydrogen this calibration, which is frequently made, is expedited by measuring the volume of expanded hydrogen from the pipet filled at some known pressure P and temperature T (usually 400 atmospheres at 0°). The capacity of the pipet is then calculated from the expression

$$V_{T,P} = \frac{V'}{\bar{P}_T} \cdot \left(\frac{P V}{\bar{P}_0 V'} \right)_{H,T,P} \quad (1)$$

where V is the capacity of the pipet and V' the volume of expanded gas at 1 atmosphere pressure P_0 , both at constant temperature T .

The change in capacity of the pipet with change in pressure is given by Love's formula³

$$\Delta V = \frac{V_0}{E(r_2^2 - r_1^2)} [3(1 - 2\mu)(P_1 r_1^2 - P_2 r_2^2) + 2(1 + \mu)(P_1 - P_2)r_2^2] \quad (2)$$

where V is the capacity of the cylinder, E is the modulus of elasticity of steel (20.4×10^5 atmos./cm.²), r_2 and r_1 are the external and internal radii of the cylinder, P_1 and P_2 are the external and internal pressures and μ is Poisson's ratio (0.287).⁴

The temperature coefficient of capacity change was derived from an equation furnished by Keyes, Joubert and Smith.⁵ The numerical values of the constants are based on data of the Reichsanstalt.

³ Love, "Mathematical Theory of Elasticity," Cambridge University Press, 1920, p. 141.

⁴ Holborn, Scheel and Henning, "Wärmetabellen," Friedrich Vieweg and Son, Braunschweig, 1919, p. 53.

⁵ Keyes, Joubert and Smith, *J. Math. Phys., Mass. Inst. Tech.*, 1, 191 (1922).

$$V_t^{F_0} = V_0(1 + 3.25 \times 10^{-5} t + 2.85 \times 10^{-8} t^2 - 1.65 \times 10^{-11} t^3) \quad (3)$$

where V_0 is the original capacity, V_t the final capacity and t the change in temperature.

Pressures are established by two gages of the dead-weight movable piston type. One of the gages has been constructed with a view to both simplicity and accuracy. The weights are supported by a scale pan hung from a saddle which transmits the load to the load bearing at the top of the oscillated piston (Fig. 2A). There are no levers. The piston diameter is 1.5875 cm. and the cylinder diameter 1.5883 cm. The effective diameter is taken as 1.5879 cm., and each atmosphere is represented by 2.0463 kg. on the piston. It has been shown by Michels⁶ that while the effective

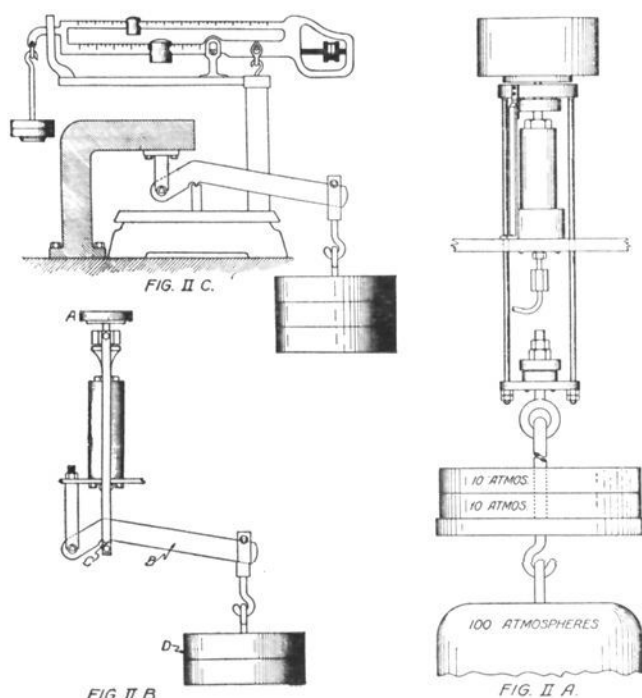

Fig. 2.—High pressure gages.

area may vary because of forces other than purely hydrostatic forces, such as the distortion of the piston under pressure, the effect is negligible at pressures below 250 atmospheres. Keyes and Dewey⁷ have made similar tests and have found a deviation of one part in 11,000 at 587 atmospheres, while Bridgman⁸ calculated a deviation of 1 part in 500 at 10,000 atmospheres. Until further data are available it will be assumed that the error introduced from this source is much less than 0.1% even at 1000 atmospheres' pressure.

The new gage has been used successfully to 200 atmospheres' pressure. The limiting factor in its accuracy is its sensitivity. This is less than 0.05 atmosphere at all pressures. The second gage, but first in order of construction, has been a standard of reference in this Laboratory for a number of years. The effective diameter of the piston as determined by direct measurement was found to be 0.24465 cm. and the effective diameter by comparison with the newer gage 0.24457 cm. One atmosphere is represented by 194.179 g. on the piston. For pressures to 100 atmospheres weights are placed directly on the piston (Fig. 2B). Higher pressures are obtained by means of a second class lever (B) with a multiplying power of approximately 5, and a series

⁶ Michels, *Proc. Acad. Sci. Amsterdam*, **26**, 805 (1923); *Ann. Physik*, **72**, 285 (1923); *Proc. Acad. Sci. Amsterdam*, **27**, 930 (1924); *Ann. Physik*, **73**, 577 (1924).

⁷ Keyes and Dewey, *J. Optical Soc. Am.*, **14**, 491 (1927).

⁸ Bridgman, *Proc. Am. Acad.*, **47**, 321 (1911).

of weights (D) each of which is equivalent to approximately 100 atmospheres' load at the load bearing (C). The effective piston load of the lever and weights has been determined in conjunction with the Bureau of Standards. The arrangement of the equipment for the calibration is shown in Fig. 2C.

"A previously calibrated counter scale was employed to measure the reactions at the load pivot of the lever, the procedure being as follows. The load bearing was placed on the platform of the scale, the fulcrum bearing rigidly anchored in level alignment with the load bearing and the scale balanced by means of the sliding counterpoise. The lever was then set in place and the resultant reaction on the load bearing measured by the use of calibrated weights on the fixed counterpoise. Similarly, the reactions caused by addition of the hanger, the hanger weight and the several weights were determined. After observing and recording the reactions at successive increments of load up to capacity (158.54 Kg) the loading was reduced by identical stages and the reactions at each decrement recorded."⁹

By this method each step in the loading was checked four times. The maximum deviation from the mean of several calibrations was 0.25% and the average deviation 0.07%.

Sources of Error and Limits of Accuracy of Results.—A critical survey of the method employed in collecting data for this report reveals two groups of possible errors: (a) the usual errors of measurement of temperature, volume and pressure; and (b) errors introduced through insufficient knowledge of the physical and chemical properties of the materials used in the investigation.

Errors in the first group should not exceed 0.1% if careful attention is given to calibration of measuring devices. However, it has been established that it is difficult to attain 0° within a heavy steel pipet completely immersed in a carefully tamped ice-water mixture, especially if the pipet is in contact with the walls of the bath. One of the pipets used in the original apparatus¹⁰ rested horizontally in the bath, each end tied to the metal walls of the container. During use at 0°, this bath was set in a second bath and the ends of the pipet were covered with ice and water to a depth of 5 cm. In spite of these precautions there is evidence that heat was conducted through the walls of the container to the pipet. The compressibility isotherms of pure nitrogen and pure hydrogen and a 3:1 mixture of these gases have been redetermined using a stirred brine bath at 0°. Results for nitrogen are lower by an average of 0.22% and for hydrogen 0.31% than those recorded in an earlier report.^{1c} The values for the 3:1 mixture differ by a maximum of 0.23% and a mean of 0.08%. This difference in the case of hydrogen and nitrogen can be ascribed to 0.6–0.8° difference in temperature. As it is not likely that so large a temperature difference existed, part of the difference may also

⁹ From the official report of the Bureau of Standards.

¹⁰ Ref. 1 b, Fig. 1.

have been due to properties inherent in the pipets which were of the same general type of metal but of different shape and cross section. The closer agreement in the case of the mixture may be due to the fact that the published values were the average results of a number of independent runs extending over a period of nearly two years.

The second group of error sources contains the more subtle factors such as (a) stress-strain relationship and volume change, (b) viscous and plastic flow and permanent set in steels, (c) temperature and volume change relationships, (d) chemical action of the gases on the pipet material, (e) solubility of the gases in the pipet material and (f) diffusion of the gases through the walls of the pipet. In view of the fact that this is but one of a series of investigations in this field, careful presentation of the complications resulting from the above disturbing factors seems justified.

(a) Love's formula, which has been used to calculate change in volume with change in pressure, was derived for cylinders, long in comparison to diameter. It neglects end effects. The cylinders used in this investigation have heavy walls which are subjected to stresses and strains of unknown magnitude due to the tension and compression effects of the plug at one end, as well as to internal stresses and strains due to the rolling of the metal and forging of the steels. However, as the calculated maximum change in volume with change in pressure is 0.13% even at 1000 atmospheres, the uncertainty introduced at temperatures to 300° should not exceed 0.05% in the final compressibility factors. Up to 300° the coefficient of elasticity of chrome vanadium steel remains constant to within 15%.¹¹ Between 300 and 400° the modulus falls rapidly, possibly as much as 40%. At 400° therefore a small additional error may be introduced.

(b) The phenomena of plastic and viscous flow and strain hardening assume importance only at the highest temperature (400°) used in this investigation. Alloys of the type used in the pipets have not been studied in relation to these phenomena. However, French¹² has found the elongation of 0.24% carbon steel at 430° to be 2.5% over a period of 300 hours under a constant load of 25,000 lb. per square inch, while 13% Cr stain resisting steel showed but a few tenths of a per cent. elongation under similar conditions. It appears that no appreciable error can be introduced by neglecting the small changes caused by these factors during the few minutes in which the stress in the pipet reaches 15,000–20,000 lb. per square inch. This conclusion is substantiated by the results of calibration of the pipet before and after use at high pressure and temperature. No difference in size of the pipet has been observed.

(c) The accuracy of the temperature capacity correction for the pipet depends entirely upon the accuracy of the equation in expressing the relation of temperature and capacity at temperatures to 400°. The temperature correction at 400° is 1.65%. An error of 6% in the correction would be required to introduce an error of 0.1% in results.

(d) Errors introduced through apparent change in capacity of the pipet through formation and subsequent decomposition of nitrides and hydrides in the walls of the pipet are apparently negligible. While the literature contains many references to

¹¹ French, *Bureau of Standards Technologic Paper No. 205*, 1921; also private communication from J. S. Vanick, formerly of the Bureau of Standards.

¹² French, "Methods of Test in Relation to Flow in Steels at Various Temperatures," Preprint, 1926, American Society for Testing Materials.

nitride formation when iron and pure nitrogen are brought together at temperatures above 600°, ¹³ Noyes and Smith¹⁴ have shown that at 460° the dissociation pressure of iron nitride (formed by action of NH₃ on iron) is greater than 20,000 atmospheres. The nitrides of chromium and vanadium, if formed at all, at 400°, would be stable compounds without appreciable effect on the capacity of the pipet. Baur and Voerman¹⁵ give the dissociation pressure of chromium nitride as about 100 mm. at 800°. Slade and Higson¹⁶ report the dissociation pressure of vanadium nitride to be "not greater than 0.2 mm." at 1203°. There seem to be no stable hydrides of iron or the alloying metals. It is well known, however, that hydrogen forms hydrocarbons with the carbon in the steel at 475°, and this reaction may occur at lower temperatures. It is probable that the hydrogen within the pipet at high temperatures contains traces of hydrocarbons. The time of contact is short, and the effect on the compressibility measurements is believed to be negligible.

(e) (f) The phenomena of gas solubility in metals and the rate of diffusion are so closely allied in their practical effects that they will be considered together. Nitrogen is generally present in steel. Data available, all at pressures below 200 atmospheres, indicate that nitrogen is "absorbed" by iron at elevated temperatures.¹³ The amount absorbed is reported to be from 0.004%¹⁷ found in a reduced iron sponge after eighteen hours' treatment at atmospheric pressure and 450°, to 0.3% found by Andrews¹⁸ in massive iron cooled from the molten condition after long treatment with nitrogen at 200 atmospheres' pressure. The gas absorbed at 450° seems to have been entirely reclaimed by the use of a vacuum pump and was probably "adsorbed" on the very large exposed surface, a surface roughly calculated to be 2.5×10^5 sq. cm. to a gram of iron. At the higher temperatures the presence of nitrogen may be explained by solid solution, chemical combination with the alloying metals or the presence of hydrogen from some decomposable compound of hydrogen and subsequent catalytic formation of ammonia. Doubtless there are adsorption effects on the walls of the pipet. The exposed area, however, is of such magnitude (about 30 cm.²) that even should the adsorption be proportional to pressure at 1000 atmospheres, the amount of gas involved would be less than 0.005 cc. (S. T. P.) at 450°. At the lower temperatures the amount would be larger but should introduce no appreciable error even at 0°. Ryder¹⁹ could detect no diffusion of nitrogen through steel at temperatures below 500°. Even at 1200° the diffusion rate is very slow. No appreciable error in the results of the present investigation should therefore arise from solubility and diffusion phenomena in the case of nitrogen.

Facts concerning the solubility and rate of diffusion of hydrogen through iron and steel are somewhat better established. It is well known that hydrogen released at an iron cathode of an electrolytic cell quickly penetrates to a considerable depth in the electrode, even at room temperature.²⁰ Diffusion of this nature is apparently due to the presence of atomic hydrogen. Similar diffusion effects due to thermal dissociation of

¹³ Sawyer, *Trans. Am. Soc. Steel Treating*, **8**, 291 (1925), a review with 60 references; Guillet, *Compt. rend.*, **182**, 903 (1926).

¹⁴ Noyes and Smith, *THIS JOURNAL*, **43**, 475 (1921).

¹⁵ Baur and Voerman, *Z. physik. Chem.*, **52**, 473 (1905).

¹⁶ Slade and Higson, *J. Chem. Soc.*, **115**, 215 (1919).

¹⁷ From an unpublished report of the Fixed Nitrogen Research Laboratory.

¹⁸ Andrews, *Engineering*, **94**, 860 (1912).

¹⁹ Ryder, *Elec. J.*, **17**, 161 (1920).

²⁰ Schmidt and Lucke, *Z. Physik*, **8**, 152 (1922); Edwards, *J. Iron Steel Inst.*, (advance proof), Sept., 1924; *C. A.*, **18**, 3348 (1924); Bodenstein, *Verhandl. deut. physik. Ges.*, **3**, 40 (1922).

hydrogen in steel become appreciable at 200°²¹ and fairly rapid at 500°. The solubility (c) of hydrogen in steel in g. per cc. of iron²² is given by the expression

$$c = \alpha e^{-\beta/T} \sqrt{P} \quad (4)$$

in which α and β are constants, T is the absolute temperature and P the pressure in atmospheres. From an extrapolation of the curve presented by Borelius based on data obtained by Sieverts, it appears that at 1 atmosphere pressure and at 300°, the solubility of hydrogen is 1.2×10^{-6} g. per cc. of iron. Assuming the above expression to hold at 1000 atmospheres the solubility of hydrogen at this high pressure is 38.6×10^{-6} g. per cc. of iron, which corresponds to a volume (S. T. P.) of 0.44 cc. The actual effect of this dissolved gas on the apparent volume of the pipet can be estimated only if the rate of diffusion be known. Charpy and Bonnerot²³ observed no diffusion of hydrogen through the walls of a tube with a thickness of 0.5 mm. under 1 atmosphere pressure at temperatures below 325°. However, results obtained by extrapolating Lombard's data²⁴ from above 400° show that at 300° the rate of diffusion through a disk of electrolytic iron 0.162 mm. thick should be at the rate of 5.6 cc. (S. T. P.) per cm.² per hour, at 1 atmosphere pressure. Lombard also found that at pressures to 1.5 atmospheres the rate of diffusion is proportional to the square root of the pressure and inversely proportional to the thickness of the metal.²⁵ Assuming the pressure-diffusion relationship to hold at 1000 atmospheres, there might have passed through the 0.162 mm. inner layer of the pipet chamber 88 cc. of hydrogen per minute. The pipet wall is 25.4 mm. thick. Assuming the wall thickness diffusion relationship to hold and taking into account the cylindrical form of the pipet, about 2.5 cc. of gas may escape from the outer wall per minute.

A laboratory experiment intended to determine the loss of gas by diffusion has been carried out. The pipet was filled at 1000 atmospheres' pressure at 300° and allowed to stand for one hour. The amount of gas after expansion was 1.5% less than when expansion was made immediately after closing the valves. This loss is 0.025% per minute, which on the total volume of about 2000 cc. (S. T. P.) is 0.5 cc. The difference between calculated and observed results may easily be due to the physical differences of electrolytic iron and hot rolled and forged chrome vanadium steel.

If the above assumptions and calculations lead to results of approximately the right magnitude, it is evident that at high pressure saturation of the metal takes place rapidly and that at 300° diffusion through the wall is comparatively slow. At 400° the solubility of hydrogen is increased two-fold and the diffusion rate four-fold. In practice the pipet is generally kept under pressure for ten to fifteen minutes before the valves are closed, thus giving ample time for diffusion of the gas through the inner walls. As the gas is expanded from the pipet, doubtless part of the dissolved hydrogen returns to the pipet chamber and is measured. Such degassing must take place quickly, for at this temperature no continued evolution of gas has been observed after the two or three minutes required for the expansion. Thus, while there is a small loss of gas through diffusion during the time required for expansion, there is a gain in the apparent size of the pipet due to solution and subsequent recovery of the gas. The first effect will predominate in a comparatively thin-walled cylinder such as was used by Holborn and Otto²⁶ and the latter effect may predominate in a thick-walled cylinder. This may

²¹ Sieverts, *Z. physik. Chem.*, **60**, 129 (1907); Ryder, *Electric J.*, **17**, 161 (1920).

²² Borelius, *Ann. Physik*, **83**, 121 (1927).

²³ Charpy and Bonnerot, *Compt. rend.*, **154**, 592 (1912); **156**, 394 (1913).

²⁴ Lombard, *ibid.*, **184**, 1557 (1927).

²⁵ Lombard, *ibid.*, **184**, 1327 (1927).

²⁶ Holborn and Otto, *Z. Physik*, **23**, 77 (1924).

account in part for the fact that Holborn's compressibility factors appear too large at temperatures above 200°, while in the present investigation there is evidence that the compressibility factors may be too small.

For example, at some high pressure, in the case of nitrogen, if volume be plotted against temperature, a curve is obtained which departs but slightly from the rectilinear, but the curvature is appreciable at all temperatures from 0 to 400° and greatest in the lower temperature ranges. In the case of hydrogen, the curvature is scarcely detectable at the temperatures below 200°. It may be that the unexpected break in the curve at 300° results from solubility and diffusion effects. For instance, 1.4 cc. (S. T. P.) less of expanded hydrogen at 100 atmospheres and 3.4 cc. less of expanded hydrogen at 300 atmospheres would have resulted in a rectilinear V - T relationship, while at 400° the amounts are 4.6 and 8.4 cc. These volumes of gas could be accounted for as dissolved in the first centimeter of the wall thickness.

With all known sources of inaccuracy taken into account, the limit of error in the results obtained with nitrogen to 400° should not exceed 0.3% and it is believed that average results may be depended upon to within 0.1–0.2%. The same limits hold for hydrogen to 200°. At 300°, the error may reach 0.4–0.5%, and at 400° the results are so irregular that they are presented only as experimental data without claim for high degree of accuracy.

Experimental Results

The experimental results of this investigation are presented in Tables I, II and III. In the compressibility factor, PV/P_0V_0 , PV is the pressure volume product of a given gas mass under the conditions of the experiment, while P_0V_0 is the pressure volume product of the same gas mass at 0° and 1 atmosphere pressure. It has been assumed that at pressures near to atmospheric, nitrogen, hydrogen and their mixtures conform to the laws of the ideal gas. The values given in the tables at 1 atmosphere are calculated on this basis. Where comparative data are available from other sources²⁷ they are included in the tables together with the name of the investigator. In some instances short interpolations or extrapolations have been necessary to bring these groups of results under comparable conditions. A comparison of the new results with those of Holborn at 50 and 100 atmospheres' pressure and temperatures to 400° shows maximum deviations for nitrogen and hydrogen of 0.30 and 0.33% and mean deviations of 0.08 and 0.18%, respectively. At pressures from 100 to 1000 atmospheres and temperatures to 200° the maximum deviations from the results of Amagat are 0.60 and 0.69% and the mean deviations 0.30 and 0.39%, respectively.

²⁷ (a) Amagat, *Ann. chim. phys.*, [6] **29**, 68 (1893); (b) Holborn, *Ann. Physik*, **63**, 674 (1920); (c) Onnes, *Comm. Phys. Lab. Univ. Leiden*, No. 169 D (1924); (d) Witkowski, *Krauhauer Anzeiger*, 305 (1905); (e) Smith and Taylor, *THIS JOURNAL*, **45**, 2113 (1923); also **48**, 3122 (1926); (f) Vershoyle, *Proc. Roy. Soc. (London)*, **111A**, 552 (1926); (g) Holborn and Otto, *Z. Physik*, **23**, 77 (1924).

TABLE I
THE COMPRESSIBILITY FACTORS, PV/P_0V_0 , FOR NITROGEN

Press., atm.	Observer	0°	50°	99.85°	198.9°	299.8°	399.3°
1		1.0000	1.1831	1.3656	1.7283	2.0978	2.4621
50	Bartlett	0.9846	1.1888	1.3888	1.7683
	Holborn	.9852	1.1886	1.3846	1.7656	2.1461
	Smith and Taylor	.9835	1.1863	1.3826
	Vershoyle	.9840
	Onnes	.9846
100	Bartlett	.9846	1.2046	1.4114	1.8071	2.1978	2.5729
	Amagat	.9910
	Holborn	.9856	1.2045	1.4118	1.8065	2.1953	2.5725
	Smith and Taylor	.9830	1.1985	1.4049	1.7985
	Vershoyle	.9842
200	Bartlett	1.0365	1.2742	1.4958	1.9073	2.3119	2.6944
	Amagat	1.0390	1.4908	1.9040
	Smith and Taylor	1.0340	1.2580	1.4754	1.8830
	Vershoyle	1.0346
300	Bartlett	1.1335	1.3711	1.5971	2.0169	2.4279	2.8166
	Amagat	1.1360	1.5923	2.0120
400	Bartlett	1.2557	1.4870	1.7112	2.1407	2.5498	2.9422
	Amagat	1.2570	1.7078	2.1300
600	Bartlett	1.5214	1.7473	1.9650	2.3914	2.8034	3.1949
	Amagat	1.5260	1.9563	2.3815
800	Bartlett	1.7959	2.0155	2.2273	2.6510	3.0615	3.4559
	Amagat	1.7980	2.2218	2.6375
1000	Bartlett	2.0641	2.2825	2.4942	2.9165	3.3195	3.7196
	Amagat	2.0685

TABLE II
THE COMPRESSIBILITY FACTORS, PV/P_0V_0 , FOR HYDROGEN

Press., atm.	Observer	0°	50°	99.85°	198.9°	299.1°	399.3°
1		1.0000	1.1831	1.3656	1.7283	2.0952	2.4621
50	Bartlett	1.0330	1.2182	1.4026	1.7684
	Holborn	1.0311	1.2161	1.4000	1.7620
	Vershoyle	1.0311
	Witkowski	1.0309
	Onnes	1.0294
100	Bartlett	1.0639	1.2521	1.4359	1.8030	2.1700	2.5141
	Amagat	1.0690
	Holborn	1.0640	1.2498	1.4339	1.7971
	Vershoyle	1.0637
200	Bartlett	1.1336	1.3272	1.5105	1.8804	2.2502	2.6054
	Amagat	1.1380	1.5163	1.8791
	Vershoyle	1.1313
300	Bartlett	1.2045	1.3986	1.5836	1.9556	2.3240	2.6800
	Amagat	1.2090	1.5886	1.9511

TABLE II (Concluded)

Press., atm.	Observer	0°	50°	99.85°	198.9°	299.1°	399.3°
400	Bartlett	1.2775	1.4720	1.6563	2.0295	2.3977	2.7625
	Amagat	1.2830	1.6616	2.0251
600	Bartlett	1.4226	1.6160	1.7999	2.1726	2.5394
	Amagat	1.4315	1.8068	2.1713
800	Bartlett	1.5665	1.7582	1.9415	2.3157	2.6762
	Amagat	1.5775	1.9518	2.3151
1000	Bartlett	1.7107	1.9006	2.0839	2.4568	2.8125
	Amagat	1.7200	2.0958

TABLE III

THE COMPRESSIBILITY FACTORS, PV/P_0V_0 , FOR A 3:1 HYDROGEN-NITROGEN MIXTURE

Press., atm.	Observer	0°	25°	50°	99.85°	198.9°	299.8°
1		1.000	1.0915	1.1831	1.3656	1.7283	2.0978
50	Bartlett	1.0269	1.1219	1.2144	1.3992	1.7676
	Vershoye	1.0276
100	Bartlett	1.0583	1.1543	1.2495	1.4298	1.8065	2.1757
	Vershoye	1.0570
200	Bartlett	1.1278	1.2200	1.3282	1.5068	1.8915	2.2659
	Vershoye	1.1244
300	Bartlett	1.0264	1.2995	1.4034	1.5870	1.9741	2.3519
400	Bartlett	1.2890	1.3805	1.4862	1.6700	2.0531	2.4356
600	Bartlett	1.4587	1.5510	1.6577	1.8412	2.2283	2.6086
800	Bartlett	1.6342	1.7215	1.8277	2.0130	2.3958	2.7765
1000	Bartlett	1.8029	1.8904	1.9964	2.1865	2.5648	2.9495

Practical Application of the Data

Practical application of the results presented in Tables I to III may be illustrated as follows. (a) The volume occupied by a known gas mass at any pressure and temperature within the scope of the table may be calculated from the expression

$$V'_{P,T} = \frac{V_0}{P} \cdot \left(\frac{PV}{P_0V_0} \right)_{P,T} \quad (5)$$

where $V'_{P,T}$ is the volume of compressed gas at pressure P and temperature T , V_0 the volume of the gas at atmospheric pressure and 0° , P the total pressure and $(PV/P_0V_0)_{P,T}$ the compressibility factor of the gas at P and T .

(b) The pressure exerted by a known gas mass at any volume, V' , and temperature, T , is most conveniently determined by graphical method. In the expression

$$\left(\frac{PV'}{P_0V_0} \right)_T = f(P) \quad (6)$$

V' is the desired volume of the compressed gas. By assuming different values for P , a series of values is obtained for $(PV'/P_0V_0)_T$. These are plotted against pressure on a pressure-compressibility factor diagram for

a gas of the same composition and at temperature T . The pressure exerted by the gas is the pressure indicated at the intersection of the curves.

(c) The density of any gas at any desired pressure P , and temperature T , may be calculated from the expression

$$\rho_{P,T} = \rho_0 P \left(\frac{P_0 V_0}{P V} \right)_{P,T} \quad (7)$$

where $\rho_{P,T}$ is the density of the gas at P and T , and ρ_0 is the density at 1 atmosphere pressure and 0° . Until it can be established that some one of the numerous equations of state already developed apply to these gases

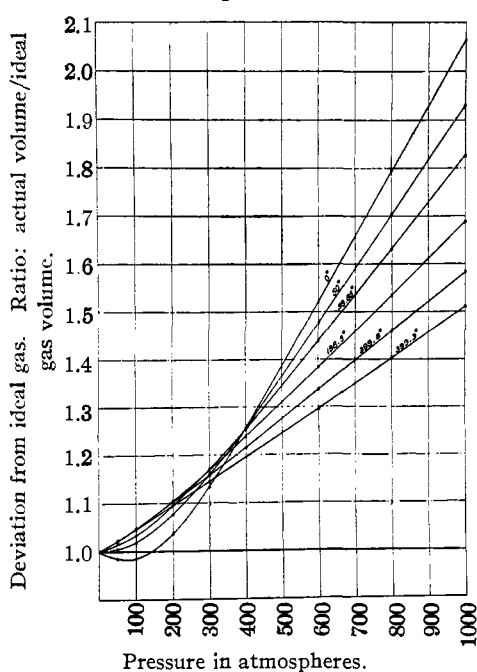

Fig. 3.—Nitrogen. Deviation from Boyle's law. $(PV/P_0V_1)_T$ in which $(P_0V_1)_T$ is the pressure volume product at 1 atmosphere and temperature T .

throughout the pressure and temperature range included in this report, or until a new equation of state is developed, rectilinear interpolation for values at temperatures and pressures not shown in the table may be employed without introduction of large errors.

At pressures of 400 atmospheres and below in the case of nitrogen, the deviation ratio increases with temperature to a maximum followed by a gradual decrease. Above 400 atmospheres the deviation ratio decreases with temperature. The deviation ratio of hydrogen, on the other hand, decreases with temperature at all pressures and temperatures covered in this investigation and this deviation ratio is very nearly inversely proportional to the absolute temperature.

The Additive Rule of Volumes and Pressures.—The additive rule implies that (a) the volume occupied by a mixed gas at pressure P and temperature T is equal to the sum of the volumes of the constituents, each at

Temperature and Deviations from the Laws of the Ideal Gas.—All gases become "ideal" under the limiting conditions of zero pressure and infinite temperature. Gases under high pressure approach the "ideal" but slowly with rise in temperature. The family of curves shown in Fig. 3 pictures the deviation of nitrogen at temperatures from 0 to 400° . Pressure is plotted against the ratio

pressure P and temperature T . (b) The pressure exerted by a mixed gas at volume V and temperature T is equal to the sum of the pressures of the constituents, each at volume V , and temperature T . The additive pressure rule (b), as given, is Dalton's law of partial pressure modified by Gibbs.²⁸ In this form it was used by Masson and Dolley²⁹ in their study of mixtures of argon, ethylene and oxygen.

It is well known that the values calculated on these premises rarely agree with experimental results. In the case of nitrogen and hydrogen and the 3:1 mixture of these gases in the pressure-temperature range investigated, the maximum deviation (1.66%) from the additive volume rule occurs at about 200 atmospheres' pressure and 0° (Table IV). At 200-300°, the deviation is of a magnitude scarcely greater than experimental error. No attempt has been made to calculate data for a similar complete table for the deviation from the additive pressure rule. However, in a single instance at 50°, the calculated (750 atm.) and actual (977 atm.) pressures of a 3:1 hydrogen-nitrogen mixture differ by 23.2%. The deviation is less at lower pressures. It is not difficult to explain this phenomenon if it is understood that in calculating the pressure for the one the rule ignores the so-called van der Waals "b" value of the second gas and the "a" value of the gases for each other.

TABLE IV

PERCENTAGE DEVIATIONS FROM THE RULE OF ADDITIVE VOLUMES

The volume of the 3:1 hydrogen-nitrogen mixture is greater than the sum of the volumes of the pure gases by percentages shown.

Press., atm.	0°	50°	99.85°	198.9°	299.8°
50	0.58	0.29	0.25	-0.05	..
100	1.34	.74	.47	.14	-0.06
200	1.66	1.07	.68	.23	-.07
300	1.65	0.83	.66	.16	.01
400	1.34	.70	.60	-.20	-.08
600	0.78	.54	.33	.04	.05
800	.64	.28	.19	-.15	.08
1000	.21	.03	.00	-.27	.28

It is interesting to note that a much closer agreement between calculated and observed results is obtained if the additive pressure rule be expressed, "At constant temperature the pressure exerted by one constituent in a gaseous mixture equals the product of its mole fraction and the pressure it would exert as a pure gas at a molecular concentration equal to the molecular concentration of the mixture." For instance, in the case of a 3:1 hydrogen-nitrogen mixture the following expression may be used.

$$\frac{3 \left(\frac{PV}{P_0 V_0} \right)_{\text{H}_2} + \left(\frac{PV}{P_0 V_0} \right)_{\text{N}_2}}{4} = \left(\frac{PV}{P_0 V_0} \right)_{3\text{H}_2, \text{N}_2} \quad (8)$$

²⁸ Lurie and Gillespie, *THIS JOURNAL*, **49**, 1146 (1927).

²⁹ Masson and Dolley, *Proc. Roy. Soc. (London)*, **103A**, 524 (1923).

V in each term represents the same molecular volume and hence the gases are present in identical molecular concentration. The deviation from this rule is less than 2% in the pressure range studied and at temperatures to 200°. The deviation seems to increase with increasing pressure and decrease with increasing temperature.

The authors take pleasure in acknowledging the friendly coöperation of the staff of the Fixed Nitrogen Research Laboratory in the solving of the many problems of this investigation. Especially are we indebted to W. E. Deming for mathematical study of the solubility of hydrogen in steel, and to W. H. Edwards and J. R. Dilley who assisted in the designing of the high pressure equipment and to the expert technicians who were instrumental in its building.

Summary

The compressibility isotherms of nitrogen, hydrogen and a 3:1 mixture of these gases have been determined through a pressure range of 1000 atmospheres and a temperature range of 400°.

The additive volume rule in the case of these gases apparently holds within the limits of experimental error at a temperature of 300°. At lower temperatures there is decided deviation.

The additive pressure rule is discussed in its various forms and is shown to hold to within 2% if defined as follows. "The pressure exerted by one constituent in a gaseous mixture equals the product of its mole fraction and the pressure it would exert as a pure gas at a molecular concentration equal to the molecular concentration of the mixture."

Some suggestions for the practical use of the experimental data are presented.

WASHINGTON, D. C.

[CONTRIBUTION FROM THE DEPARTMENT OF CHEMISTRY, THE PENNSYLVANIA STATE COLLEGE]

THE EQUILIBRIUM OF NITROGEN AND HYDROGEN WITH AMMONIA IN A CORONA DISCHARGE

BY GERALD L. WENDT AND J. E. SNYDER

RECEIVED FEBRUARY 2, 1928

PUBLISHED MAY 5, 1928

The synthesis and decomposition of ammonia under the action of electric discharges were early observed.¹ Equilibrium studies were first reported by Berthelot² who found that 3% of ammonia by volume resulted under the action of the silent discharge. From studies of reaction rate,

¹ (a) Deville, *Compt. rend.*, **60**, 317 (1865); (b) Chabrier, *ibid.*, **75**, 484 (1872); (c) Thenard, *ibid.*, **76**, 983 (1873); (d) Donkin, *Proc. Roy. Soc. (London)*, **21**, 281 (1873); (e) de Hemptinne, *Z. physik Chem.*, **22**, 358 (1897).

² Berthelot, *Bull. soc. chim.*, [2] **26**, 101 (1876).